

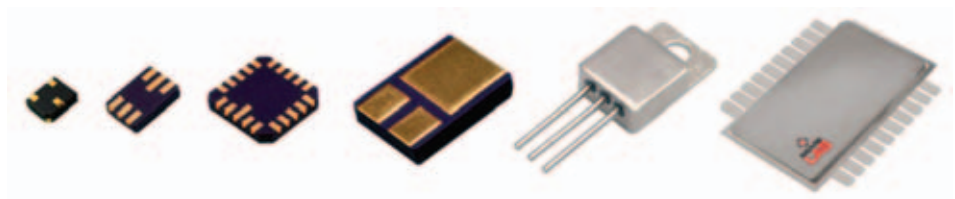

Space Products

Semelab products and processes for space applications

AEROSPACE





Contents

1. Introduction	4
2. Programmes Supported	5
3. Innovations	6
3.1 Improving the Space Weather Forecast with the LCC1- 4	6
3.2 SoLaRfets – Radiation Tolerant MosFETS	7
3.3 Si3N4 via technology	7
3.4 Wide-Bandgap devices	8
3.5 Diode – Leadless Chip Carriers	9
3.6 Diamond Substrate	9
4. Hi-Rel COTS – Commercial Considerations	10
5. Product Range	11
6. Package Drawings	15
The following sections are extracted from Semelab document ‘High Reliability and Screening Applications’ available at www.semelab.com/sml_downloads .	
9. MIL-PRF-19500 - QR216, QR217 (Space)	17
9.1 Space Level Processed Discrete Semiconductors (QR216, QR217)	17
9.2 QR217 - Inspection levels: ‘Space Level Processed’ Conformance	18
9.3 QR216 - Screening: ‘Space Level Processed’ Components	20
10. ESA - ESCC (Space)	21
10.1 Chart F2 - Production Control	22
10.2 Chart F3 - Screening Tests	23
10.3 Chart F4 - Qualification and Periodic Tests	24
11. Screening & Approval Comparison Tables	25
11.1 Comparison of Space Level Screening Options	25
11.2 Comparison of Space Level Die Lot Approval Procedures	26
11.3 Comparison of High-Rel Screening Options	27

1. Introduction

Experience and Innovation In Semiconductor Technology

At SEMELAB, we research, design, manufacture and distribute an innovative range of semiconductor products throughout the world.

Our R&D teams have an excellent track record for developing imaginative electronic solutions and our design engineers have created a wealth of high performance products. Our manufacturing divisions have ensured supreme quality and reliability. And our sales teams and distribution partners have opened international markets to some of the best electronics solutions available.

At Semelab we have many year's experience of the design and manufacture of supplying semiconductor solutions for use in space applications. All design and manufacturing is carried out in Semelab's UK custom built facility.

There are a wide range of discrete semiconductors available: Bipolar, SoLaRfets, MOSfets, J-FETs, Linear Regulators and Diodes. These are available in many different package options: small ceramic surface mount; multi pad ceramic surface mount; power ceramic, metal hermetic packages. Details of the different package outlines and range of products are included in the following pages.

Also available are a range of standard and custom MCAs (Multi Chip Arrays). These integrate several semiconductor die or other components into one package to provide a light weight, space saving and improved-reliability alternative to discrete circuits. There are a range of package styles available for small signal and power applications. These are cost effective solutions with little or no NRE and similar lead times to standard discrete products. The different package styles are included in the following pages.

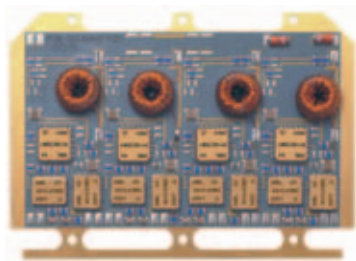

Example circuit based on Semelab MCAs (picture courtesy of Comdev)

2. Programmes Supported

Over recent years many different Semelab products have been used in major Space programmes including the following:

ENVISAT	LCC1, Small Signal
IMMARSAT	LCC1, Small Signal, TO18, High Speed Zener, Schottky Diode
EMS	LCC1 Small Signal
ASTRA	LCC1, LCC2, Small Signal (dual)
SOHO CLUSTER	J-FETs
FIAR	TO59 – Bipolar power
KOREA SAT	LCC1, Small Signal, J-FETs, Zener, Schottky Diodes
SPOT / HELIOS	LCC1, Small Signal, J-FETs, Diodes
SKYNET	TO18 / TO39 – Small Signal
ARTEMIS	LCC1, LCC2, LCC4
ODYSSEY	MCAs
MIMR	MCAs
GLOBAL STAR	MCAs - Analogue Arrays
MSG	MCAs
METOP	MCAs, Linear Regulators
ROSETTA	Small Signal LCC1
ATV	TO18 / 39
ISS	Bipolar TO39 / TO66 , MCAs
SMART 1	Digital voter circuit, Dual Bipolar, LCC2
RAINBOW	MCA, Small Signal devices
SIRAL	Small Signal - JFET, LCC1
GALILEO	MCA, Small Signal devices
ARRIANE VEGA	Power Module
ALTIKA	SoLaRfet©, MCA
SKYNET	MCA, Small Signal devices
SENTINEL	MCA, LCC1, SoLaRfet© (Power MOSfets), Small Signal devices
BEPI-COLUMBO	LCC1, Small Signal device

3. Innovations

Semelab has always been at the forefront of innovation. For many years our R&D teams have been coming up with imaginative electronic and packaging solutions. Over the years many of these solutions have become incorporated into our standard range of products with a wide and extensive range of applications. This section gives details of some of our recent developments.

3.1 Improving the Space Weather Forecast with the LCC1- 4

As spacecraft navigate the oceans of space, satellites encounter severe storms in a 'similar' way as Earth based ocean going vessels do.

A documented phenomenon known as Deep Dielectric Discharge, associates high speed solar wind streams with the appearance of large numbers of highly energetic electrons in the magnetosphere. These high energy electrons are dangerous to the operation of the spacecraft as they bury themselves into dielectric materials deep within the satellite, (materials such as PCB materials, coaxial cables etc).



The build-up of charge occurs when the total amount of high velocity electrons exceed 1MeV (1 Million electron Volts) during the storm event. The charge continues to build-up until the dielectric strength of the material is exceeded. Once this happens an instantaneous electrical discharge occurs, which is similar to a miniature lightning strike. This is a hazardous event capable of damaging semiconductor and other sensitive devices.

Part of the solution is to incorporate design improvements to mitigate the effects of Deep Dielectric Discharge. Semelab are currently offering LCC1-4 (Leadless Chip Carrier Number 1, 4 pads), which is based on the ESA qualified ceramic chip carrier technology, but has an additional feature which electrically connects the metal lid of the discrete device, to an additional solder pad at the base of the package, so the lid can be electrically connected to a known potential, (usually ground), therefore conducting away the charge as it occurs.

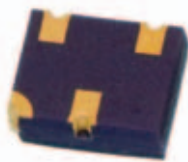

Deep Dielectric Discharge: LCC1- 4 package



LCC1- 4 package – internal view

The full range of products that are available in the standard LCC1 package are also available in the Deep Dielectric Discharge LCC1-4 package. Section 4 contains details of products supplied in the past. Contact Semelab Sales for further information.

3.2 SoLaRfets

The Semelab SoLaRfet has been specifically developed to provide a radiation tolerant MosFET for use in space applications. The development is an extension of one of our existing MosFET processes which has been sold in high volumes over many years.

The structure of the device has been modified to enhance the DC performance and give good SEU characteristics. The device is ideally suited for fast switching applications in harsh environments.

Semelab has also made developments in the substrate and package technology to further optimise the performance of finished devices. Contact Semelab sales for further information.

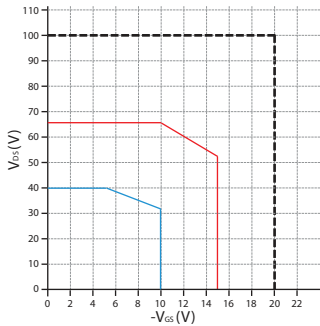

ION	LET	ENERGY MeV	RANGE um Si
Argon	14.1	150	42
Krypton	34	316	43
Xenon	55.9	459	43

Ar = 14.1 MeV mg⁻¹ cm²
 Kr = 34.0 MeV mg⁻¹ cm²
 Xe = 55.9 MeV mg⁻¹ cm²

--- Argon
 — Krypton
 — Xenon



Single Event Effect Safe Operating Area

Radiation Tolerant MosFET bridge in Si₃N₄ package

3.3 Si₃N₄ Via Technology

Semelab has always been at the forefront of packaging technology, being the first to bring a number of what have now become industry standard packages to the market place. Semelab has also developed module packages (ie MCA, Power MCA and others) for combining a number of different discrete devices and/or technologies in a range of hybrid solutions.

The benefits of Semelab's modular solutions over discrete devices include: Higher density; Lighter weight; Easier interconnection; Little or No NRE; Lower cost; Fast turnaround & improved reliability.

This trend continues with the recently introduced Si₃N₄ via technology module. The package combines state-of-the-art Via technology with Si₃N₄ substrates to achieve high power performance without the use of glass seals. The package is semi-customable to enable multi-chip arrays based on circuit requirements.

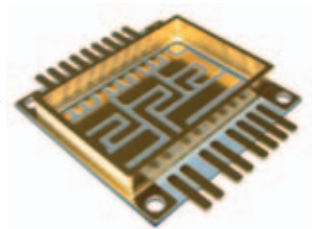

Example of the semi-customable Si₃N₄

3.5 Diode Leadless Chip Carriers (DLCC)

The DLCC family of Ceramic Leadless Chip Carrier packages for Diodes is designed for all high reliability applications – Space, Aerospace, High temperature and Military.

The DLCC package design takes full advantage of the proven high reliability pedigree of the High Temperature Cofired Ceramic (HTCC) surface mount packaging technology, which is easily integrated for automated assembly. Semelab has taken the existing standards for ceramic surface mount package manufacture and added additional design features to enhance thermal performance, to present a competitive alternative for high reliability applications.

- Fully hermetic, ceramic diode leadless chip carrier
- Replacement for MELF-style standard product with enhanced features
- Fits on existing PCB layouts
- Castellated design to ensure solder meniscus between board and component is visible
- Thermal vias incorporated in design to enhance thermal performance
- Rectangular design to aid in PCB assembly
- Designed to be a more cost effective solution
- Manufactured in accordance with MIL-19500 and ESA specifications

For more information please go to www.semelab-tt.com/dlcc.html



3.6 Diamond Substrates

Semelab has many years experience in the supply of RF MosFET. The devices are manufactured using a unique silicon Vertical DMOS process with gold metalisation which gives high performance and maximum reliability at high power levels.

The diamond substrate was originally developed for use in the RF product range to enhance the performance and reliability of the device even further. Both simulations and measurements have shown a considerable improvement in a number of areas. The most significant of these is the halving in value of the junction to case thermal resistance when compared with the Beryllium Oxide substrate normally used.

Please contact Semelab sales for further information on the use of diamond substrates in products for space use and also for information on Hermetic RF products.



Enhanced performance RF device using diamond substrate

4. Hi-Rel 'COTS' – Commercial Considerations

For many years there has been talk of COTS (commercial-off-the-shelf) products for space use. There has been much confusion over what this means. At Semelab we have only ever believed in supplying High-Reliability devices for use in space applications. However, there are a number of commercial considerations which can be applied enabling High-Rel products to be supplied in shorter lead times and at a lower overall contract cost.

Semelab works with its customers to supply the most appropriate commercial solutions for the contract requirements, ensuring best value and continuity of supply.

4.1 Space Kanban

Semelab can work with its customers to supply 'kanban' solutions to meet production requirements. By placing a longer term contract, all wafer or die can be procured and reserved ensuring consistency of product over the full production time frame. In addition a reduction of ancillary costs can be achieved by single lot radiation testing and SEM's; and a reduction of the additional costs such as 'pre-cap visual inspections' and 'buy offs' by producing larger batch quantities. Semelab will then hold fully completed stock in its bonded stores against the customer contract, available for immediate call off. Invoicing for the product will be at the time of shipping. Contact the Semelab Sales Office for further information.

Benefits of Space Kanban include:

- single wafer lot production
- reduced ancillary costs
- scope for re-scheduling
- invoicing at point of shipping.

4.2 'Off-the Shelf' Product

Semelab has a number of space products which are manufactured on a regular basis. The ongoing production of these parts means that there is often stock available 'off-the-shelf' for immediate delivery. These products are available processed to Semelab's QR217 (Space Level Full Quality Conformance Inspection and QR216 ('Space Level Discrete Component Screening)). See Section 9 for full details of QR217, QR216. (Please note that in addition, LVT's are sometimes available on these parts, but not always)

Parts Include:

**2N2222, 2N2369, 2N2484, 2N2857, 2N2894, 2N2907
2N4391, 2N4392, 2N4393**

4.3 Wafer & Die Storage

To ensure long term availability of product supply Semelab can procure any volume of wafer or die on behalf of a customer. This will then go through immediate qualification and be held in storage for the sole use of that customer. This practice has been successfully employed by Semelab for many years.



5. Product Range

Semelab have provided many products types in the past for space applications:

BIPOLAR:

2N2219A	TO39	ESCC 5201 003 02C
2N2222A	TO18	ESCC 5201 002 01B (&C)
2N2222ACSM	LCC1	ESCC 5201-002-05C 66-LC-0147 01B TPR-12-034 MA500 AJB STR01-020-01 66-LC0147 LVL C
2N2222ADCSM	LCC2	SCC 5201 002 04B STR01-031 01B 66-LC-0190 02B
2N2369A	TO18	ESCC 5201 006 05B ESCC 5201 006 04B RA.1201.009.10 RA.1201.017.10 TPR-12-032 66-LC-0173-01 LVL B
2N2369ACSM	LCC1	ESCC 5201 006 04B (&C) ESCC 5201 006 05B RA.1201.009.10 RA.1201.017.10 TRP-12-032 66-LC-0173 01 LVL B (&C)
2N2369ADCSM	LCC2	MIL-PRF-19500/317 (QR216/7)
2N2484	TO18	SCC 5201 001 01B (&C)
2N2484CSM	LCC1	66-LC-0170 LVL B
2N2484DCSM	LCC2	66-LC-0171 LVL B
2N2857	TO18	SC 5201 014 01B (&C) 66-LC-0168
2N2857CSM	LCC1	66-LC 0176
2N2880	TO59	ESCC 5203 025
2N2894	TO18	ESCC 5201 014 01C
2N2894DCSM	LCC2	QR216 & QR217
2N2905A	TO39	ESCC 5202 002 02B (&C)
2N2907A	TO18	ESCC 5202 001 01B
2N2907ACSM	LCC1	ESCC 5202 001 04B (&C) 66 LCO145 LVL B (&C) MA-5000-AJC STR-021-01 TPR-12-030 RA.1202.008.11A
2N2907ADCSM	LCC2	ESCC 5201 001 1000 017 576 66-LC0189 02B STR01-032
2N2908X	TO53	IGG-290-874 01B
2N2920	TO77	SCC 5207 002 02B (&02C)
2N2920A	TO77	SCC 5207 002 03B
2N2920ADCSM	LCC2	SCC 5207 002 12B
2N3019	TO39	SCC 5201 011 02C SCC 5201 011 03B STR01-019-02B
2N3019CSM	LCC1	SCC 5201 011 02C SCC 5201 011 03B STR01-019-02B
2N3439	TO39	ESCC 5203 011 02B
2N3467	TO39	ESCC 5208 009 01

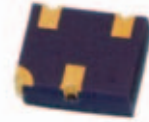

LCC1

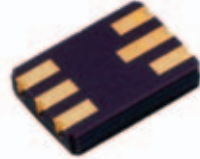

LCC2



SMD05



TO257



TO18



TO39

2N3501	TO39	ESCC 5201 013 02B
2N3637	TO39	ESCC 5208 003 03B (&4B)
2N3700CSM	LCC1	ESCC 5201 004 04B
2N3764	TO18	MA.500.ACK
2N3765	TO46	IGG-221-724
2N3810	TO77	ESCC 5207 005 02B (&1C)
2N3810DCSM	LCC2	66-LC0169
2N3822	TO18	IGG-232-777-02
2N3906CSM	LCC1	ESCC 5204 002 05B
2N5153	TO39	ESCC 5204 002 02B (&03B)
2N5153SMD05	SMD05	SCC 5204 002 XX MIL-PRF-19500/545D (QR216/7)
2N5153U	TO39	ESCC 5204 002 05B
2N5154X	TO39	ESCC 5203 010 04B
2N5154XSMD05	SMD05	ESCC 5203 010 04B QR217 GPS A,B,C + QR216
2N5154XSMD1	SMD1	QR217 GPS A,B,C + QR216
2N5672	TO3	SCC 5203 004 03B 66-LC0131
2N5954	TO66	IGG-221-826-01
2N6849	TO39	ESCC 5206 003 01C
2N918	TO72	ESCC 5201 009 01B
BDS16	TO257	T-120-01B (&1C)
BDS18	TO257	T-121-01B (&1C)
BDS20	TO257	SAH 0046-G200-W2
BUL54AH	TO5	RA.1203.004.10-11
BUL54A-T257	TO257	RA.1203.003.10-12
FMMT92CSM	LCC1	RA.1202.006.11

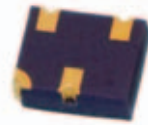

LCC1

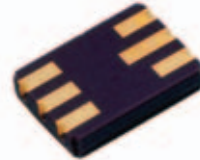

LCC2



SMD1

MCA'S

MCA0102/T	LCC6	MCA 0102 TC - CDP 9.19
MCA0102/U	LCC6	MCA 0102 UC - CDP 9.19
MCA0102/V	LCC20	MCA 0102 VC - CDP 9.19
MCA0102/W	LCC20	MCA 0102 WC - CDP 9.19
MCA0102/X	LCC20	MCA 0102 1C - CDP 9.19
MCA0102/Y	LCC20	MCA 0102 2C - CDP 9.19
MCA0102/Z	LCC20	MCA 0102 3C - CDP 9.19
MCA0301/A2	LCC6	SE5000 / MCA0301 -01
MCA0301/B	LCC6	SE5000 / MCA0301 -02
MCA0301/C2	LCC6	SE5000 / MCA0301 -03
MCA0301/D	LCC6	SE5000 / MCA0301 -04
MCA0301/E	LCC6	SE5000 / MCA0301 -05
MCA0301/F	LCC6	SE5000 / MCA0301 -06
MCA0301/G	LCC6	SE5000 / MCA0301 -07
MCA0301/H	LCC6	SE5000 / MCA0301 -08
MCA0301/J	LCC6	SE5000 / MCA0301 -09
MCA0301/K	LCC6	SE5000 / MCA0301 -10
MCA0301/L	LCC6	SE5000 / MCA0301 -11
MCA0301/M	LCC6	SE5000 / MCA0301 -12
MCA0301/N	LCC6	SE5000 / MCA0301 -13
MCA0301/P	LCC6	SE5000 / MCA0301 -14
MCA0301/Q	LCC6	SE5000 / MCA0301 -15
MCA0401/1	LCC20	IGG-160-1474-02C
MCA0616/1	LCC6	SCD 201366-1
MCA0616/2	LCC6	SCD 201366-3
MCA0616/3	LCC6	SCD 201366-5

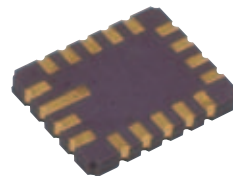

LCC6

MCA0625/1	LCC20	SCD 201366-7
MCA0625/2	LCC20	SCD 201366-9
MCA0625/3	LCC20	SCD 201366-11
MCA0625/4	LCC6	SCD 201366-13
MCA0627/1	LCC6	SCD 201366-15
MCA0627/3	LCC6	SCD 201366-17
MCA2696/1	LCC6	RA.0812.002.11B
MCA2696/2	LCC6	RA.0812.002.12B
MCA2696/3	LCC6	RA.0812.002.13B
MCA2696/4	LCC6	RA.0812.002.14B
MCA2696/5	LCC6	RA.0812.002.15B
MCA2696/A2	LCC6	TL-AM-1201-16B
MCA2696/B	LCC6	TL-AM-1201-17B
MCA2696/C2	LCC6	TL-AM-1201-18B
MCA2696/D	LCC6	TL-AM-1201-19B
MCA2696/E	LCC6	TL-AM-1201-20B
MCA2696/F	LCC6	TL-AM-1201-21B
MCA2696/G	LCC6	TL-AM-1201-22B
MCA2696/H	LCC6	TL-AM-1201-23B
MCA2696/J	LCC6	TL-AM-1201-24B
MCA2696/L	LCC6	TL-AM-1201-25B
MCA2703/1	LCC16	96-LC0071-01
MCA3201/1A	LCC6	CDP 9.90.01
MCA3201/1B	LCC6	CDP 9.90.02
MCA3201/2B	LCC20	CDP 9.90.04
MCA3201/3A	LCC6	CDP 9.90.05
MCA3201/3B	LCC6	CDP 9.90.06
MCA3201/4B	LCC20	CDP 9.90.07
MCA4003/1	LCC20	SCD-200301-1
MCA4003/2	LCC6	SCD-157592-3
MCA4003/3	LCC6	SCD-157603-5
MCA5001/5	LCC6	SCD 157592-1

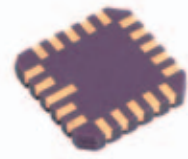

LCC20

DIODES

1N4003Q	LCC2	65-LC-0124
1N4148	LCC1	65-LC-0119 SCD 157769 TPR-04-066
1N4150	LCC1	65-LC-0134-01
1N4151	LCC1	65-LC-0134-02
1N4572	LCC1	65-LC-0132-08
1N4626	LCC1	65-LC-0145-01
1N5617	LCC1	65-LC-0133
1N5711	LCC1	QR217 GPS A,B,C QR216
45CKQ100	TO258	PO-PS-IGG-PL-0100
60CKQ045	TO258	PO-PS-IGG-PL-0063
BAS70	LCC1	SCD 201444-01
BAT54	LCC1	65-LC0118 PO-PS-IGG-PL-0189 SCD 157558 (CDP926E O1)
BZX55C15	LCC1	65-LC-0120-20 TPR-04-059-20
BZX55C33	LCC1	65-LC0120-28
BZX55C3V3	LCC1	65-LC0120-04 TPR-04-059-04
BZX55C3V9	LCC1	65-LC-0120-06
BZX55C5V6	LCC1	65-LC-0120-10

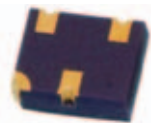

LCC1



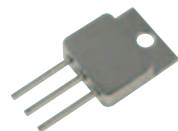

LCC2

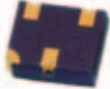

TO258

BZX55C7V5	LCC1	65-LC-0120-13	 LCC1
HP5082-2800	LCC1	65-LC-0136-01 (&02)	
HP5082-2810	LCC1	65-LC-0135-01 (&02)	
MP2835	LCC1	65-LC-0150	

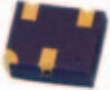
JFETS

2N4391	TO18	ESCC 5205 003 01B (&01C) MA 5000 AKW 01B 66-LC-0197	 LCC1  TO18
2N4392	TO18	ESCC 5205 003 02B (&02C)	
2N4392CSM	LCC1	ESCC 5205 003 02B RA.1205.071.10 TL-AM-023 30600050/022	
2N4393	TO18	ESCC 5205 003 03B (&03C)	
2N4393CSM	LCC1	65-LC-0153-01B 97 30600051/022	
2N4416	TO72	ESCC 5205 004 01B (&01C)	
2N5116	TO18	66-LC-0180-01	

MosFETS

2N6849	TO39	ESCC 5206 003 01B (&C)	 TO257
IRFG110	cer-dip	INM-232-312	
IRFY044	TO257	INM-232-313	
IRFY140	TO257	IGG-232-394	
IRFY240	TO257	INM-232-314	

REGULATORS

LM117H	TO39	ESCC 9102 005 06B	 LCC4
LM137	T257	44-LC-0152	
LM137	LCC4	TLAM 0814 03B	

MODULES

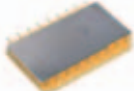
SML150FBH12ESA	custom	150A 1200V IGBT Hermetic Module	 CUSTOM
SML150HBH06ESA	custom	150A 600V 3 phase IGBT Bridge - Hermetic Module	

SoLaRfet

SFA001	custom	Radiation Tolerant MOSFET bridge in Si3N4 package	 CUSTOM
SML125F24SMD	SMD1	Radiation Tolerant FET	

6. Package Drawings

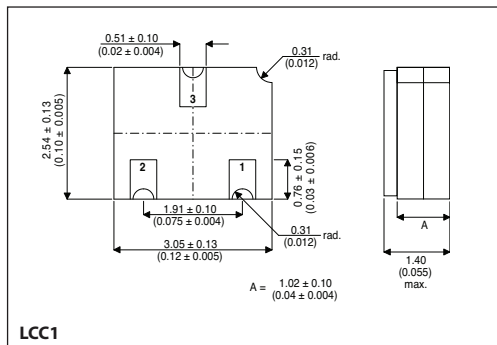

LCC1

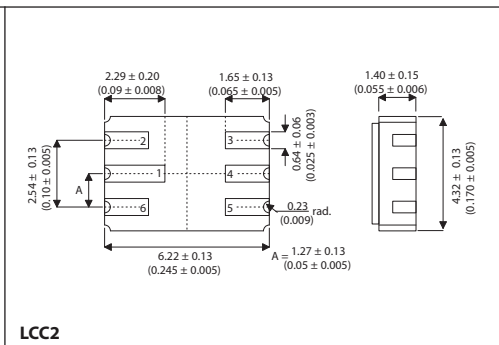

LCC2

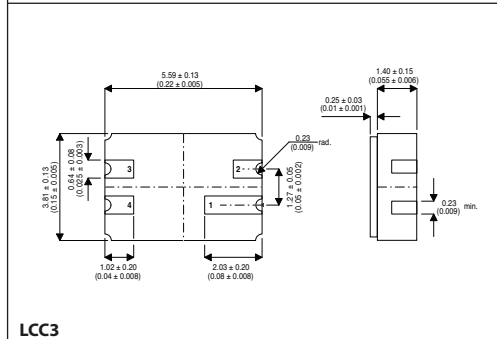

LCC3

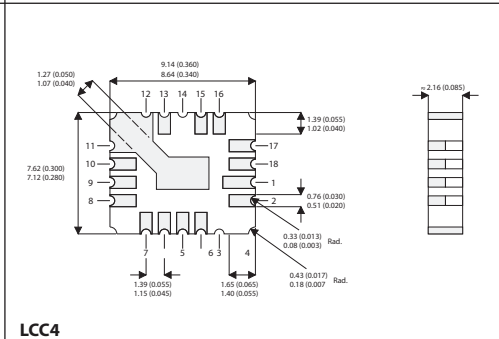

LCC4

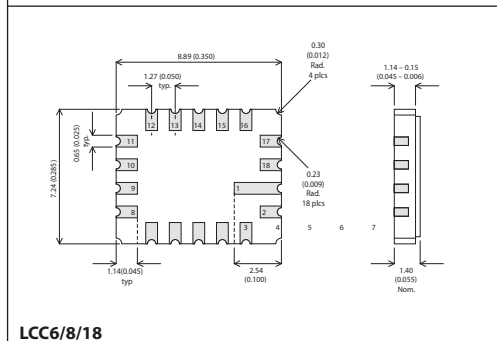

LCC6/8/18

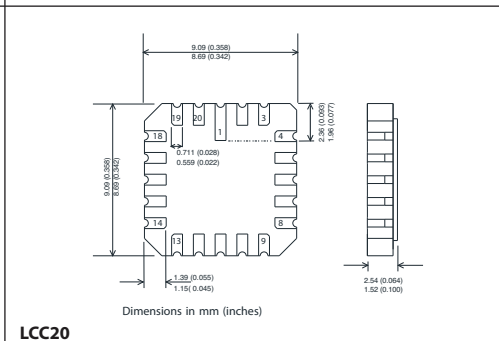

LCC20

Dimensions in mm (inches)

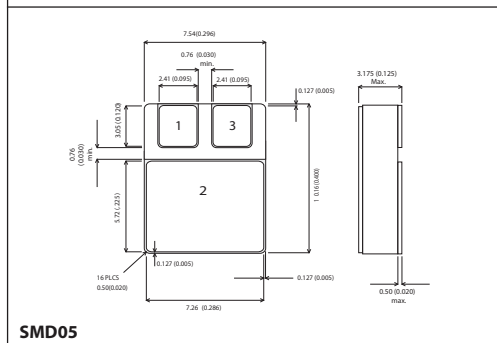

SMD05

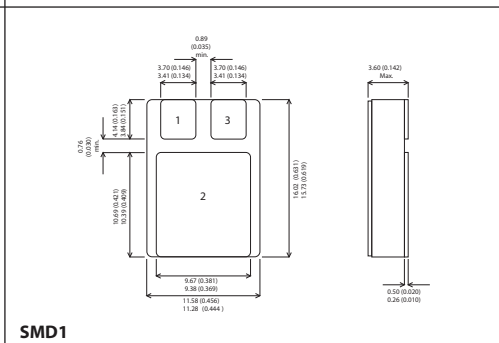

SMD1

9. MIL-PRF-19500 – QR216, QR217 (Space)

9.1 Space Level Processed Discrete Semiconductors (MIL-PRF-19500)

QR217: 'Space Level' Full Quality Conformance Inspection.

QR216: 'Space Level' Discrete Component Screening

SEMELAB's QR217 and QR216 processing specifications, in conjunction with the company's ISO9001:2000 approval present a viable alternative to American MIL-PRF-19500 space level parts supplied from a European manufacturer.

QR217 (quality conformance) is based on the quality conformance inspection requirements of MIL-PRF-19500 groups A (table V), B (table VIa), C (table VII) and also ESA / ESCC 5000 (chart F4) lot validation tests.

QR216 (screening) is based on the screening requirements of MIL-PRF-19500 (table IV) and also ESA / ESCC 5000 (chart F3). Details of QR217 and QR216 are included in the following pages.

All manufacture and processing is carried out on our approved High-Rel assembly line in Lutterworth and product is released under our ISO 9001:2000 defence standard approval.

The 'standard' JQRS part is processed to the Semelab data sheet, screened to QR216 and has conformance testing to Q217 groups A and B. Available options and the associated part number extensions are shown below. These are chargeable and must be specified at order stage. The extensions on the Semelab part numbers used reflect these additional items. Ordering Information: (example)

Part Number	Description	Marking (*)
2N2369-JQRS	QR217 groups A,B Screening to QR216	2N2369-JQRS

Additional options:

Customer Pre-Cap Visual Inspection	-CVP
Customer Buy-Off visit	-CVB
Data Pack	-DA
Group B charge	-GRPB
Group B destructive mechanical samples	-GBDM (12 pieces)
Group C charge	-GRPC
Group C destructive electrical samples	-GCDE (12 pieces)
Group C destructive mechanical samples	-GCDM (6 pieces)
Solderability Samples	-SS
Scanning Electron Microscopy	-SEM
Radiography (X-ray)	-XRAY
Total Dose Radiation Test	-RAD

Notes:

- 1) All 'Additional Options' are chargeable and must be specified at order stage.
- 2) When Group B or C is required, additional electrical and mechanical destructive samples must be ordered
- 3) All destructive samples are marked the same as other production parts unless otherwise requested.

9.2 QR217 Inspection Levels for ‘Space Level Processed’ Products

QR217: Group A - Electrical Tests

*small lot conformance

Subgroup	Description	Sample*	Reject
1	Visual + mechanical Inspection	20	0
2	DC electrical tests at 25°C	20	0
3	DC electrical tests. Hot & Cold temps as per device datasheet	45	0
4	AC electrical tests at 25°C	45	0
5	Safe Operating Area (Power Transistors) Endpoint electrical measurements	8	0

The specified parameters to be included in each subgroup shall be as per Semelab Data Sheet. Where no parameters are specified in a particular subgroup or test within a subgroup, no Group A testing is required for that subgroup or test to satisfy Group A requirements. A single sample may be used for all subgroup testing. These tests are considered non-destructive.

QR217: Group B - Short term Environmental & Endurance Tests *small lot conformance

Test	note	MIL-STD-750 method	Condition	Sample* d=destructive	Reject
Subgroup 1 Physical Dimensions		2066	As per specification	8	0
Subgroup 2 Solderability Resistant to solvents	(3) (3)	2026 1022	(minimum 3 devices) (Separate samples can be used)	6d leads 6d devices	
Subgroup 3 Thermal shock (liquid to liquid) Temperature Cycling (air to air) Hermetic seal (a) Fine Leak (b) Gross leak Electrical Measurement		1056 1051 1071	Test condition B (25 cycles) (glass diodes only) Test condition C or max stg temp, whichever is less. 100 cycles. Test condition H. <0.01cc. max = 5 x 10-9 atm cc/s, >0.01cc. max = 1 x 10-8 atm cc/s	6d	0
Internal visual design verification	(4)	2075	Visual criteria in accordance with qualified design.	6d	0
Bond strength		2037	(minimum 6 devices)	12 wires d	0
Die Shear		2017	Parts from bond strength (min=6)	6d	0
Subgroup 4 / 5 Steady-state operation life or Intermittent operation life or Blocking life Electrical Measurements	(5)	1027 1037	340hrs at specified bias conditions As specified	12	0
Subgroup 6 Thermal resistance		3131 and SML 7404	As per SEMELAB specification	6	0
Subgroup 7 High temperature life (non operating) Electrical Measurements		1032	340hrs high temperature storage As specified	12	0

(Minimum quantity of destructive samples required is 12 pieces)

(Full notes for numbered references are at the end of group C table)

QR217: Group C - Long term Environmental & Endurance Tests

*small lot conformance

Test	note	MIL-STD-750 method	Condition	Sample* d=destructive	Reject
Subgroup 1 Physical Dimensions		2066	Dimensions per case outline specified	6	0
Subgroup 2 & 3 Thermal Shock (glass strain)		1056	Test condition B (25 cycles)	6d	0
Temperature Cycling (air to air)		1051	Test condition C or max stg temp, whichever is less. (45 cycles inc. screening)		
Shock		2016	Non operating, 1500G, 0.5ms, 5 blows in each orientation, X1, Y1, Z1 (Y1 only for axial glass diodes)		
Vibration (Variable frequency)		2056			
Hermetic seal (a) Fine Leak		1071	Test condition H. <0.01cc. max = 5 x 10 ⁻⁹ atm cc/s, >0.01cc. max = 1 x 10 ⁻⁸ atm cc/s		
(b) Gross leak			b) Test condition C		
Moisture resistance		1021	Omit initial conditioning		
Terminal strength		2036	As specified		
Electrical Measurement			As specified		
Subgroup 4 Salt atmosphere (corrosion)	(2)	1041	Covered by MIL883 ongoing Group D programme	see (2) 6d	0
Subgroup 5 Thermal resistance		3131 and SML 7404	As per SEMELAB specification	6	0
Subgroup 6 Steady-state operation life		1026	1000hrs at max operating junction temp	12d	0
or Intermittent operation life or Blocking life		1036	As specified		
Electrical Measurements					
Subgroup 7 Internal Gas Analysis (corrosion)	(2)		Covered by MIL883 ongoing Group D programme	see (2) 3d 5d	0 1

(Minimum quantity of destructive samples required is 18 pieces)

- Individual subgroups may be performed on representative parts from the same package family.
- Group C subgroup 4 and 7 are covered by MIL883B ongoing group D programme. If customers require these subgroups to be done on the specific batch being covered, an additional 'Grp C extra' charge applies and an additional 11 destructive samples must be ordered. This must be specified at order stage.
- Electrical reject devices from the same inspection lot may be used for all subgroups when electrical end point measurements are not required.
- Post burn-in electrical rejects may be used.
- If a given inspection lot undergoing Group B inspection has been selected to satisfy Grp C inspection requirements, the 340 hour life test may be continued to 1000 hrs to satisfy the Group C life test requirements. In such cases, either the 340 hour end point measurements must be made as a basis for Group B lot acceptance or the 1000 hour end point measurement shall be used as the basis for both Group B and Group C acceptance.
- Internal Visual Design Verification may be omitted if the devices have been manufactured by Semelab as sample pre-cap visual inspection will have been performed.

9.3 QR216: ‘Space Level’ Discrete Component Screening

QR216: Discrete Component Screening (with reference to MIL-STD-750)

	Description	MIL-STD-750 method	Conditions	JQR-S
1	Internal Visual (Pre-cap) Inspection	2069, 207, 2072		100%
2	Customer Pre Cap Visual Inspection	2069, 2070, 2072	Customer specified option (chargeable)	100%
3	High temperature stabilisation bake	1032	24 hrs min at rated maximum storage temperature	100%
4	Temperature Cycling	1051	20 cycles at -55°C to +175°C or max storage temp (whichever is lower) with minimum 10 minutes dwell time	100%
5	Constant acceleration	2006	20,000G force in Y1axis for 1 min duration (see note 2)	100%
6	Particle Impact Noise Detection (PIND)	2052	(full yielded quantity)	100%
7	Device Serialisation		Device serialisation is carried through to shipping.	
8	Interim electrical		Read & Record	100%
9	High temperature reverse bias a) Bipolar b) Power MOSFET c) Diodes	1039 1042 1038	Test Condition A Test Condition B Test Condition A	100%
10	Interim electrical (note 3)		Read & Record, Drift Check	100%
11	Power burn-in a) Bipolar b) Power MOSFET c) Diodes	1039 1042 1038	Test Condition B - 240 hrs min Test Condition A - 240 hrs min Test Condition B - 240 hrs min (4)	100%
12	Final electricals (note 3)		Read & Record, Drift check (1)	100%
13	a) Hermeticity – Fine b) Hermeticity - Gross	1071 1071	Test condition H. Max leak rate =5x10 ⁻⁸ atm cc/s, (5x10 ⁻⁷ atm cc/s for internal cavity <0.3cc) Condition C	100% 100%
14	Radiographic tests (X-Ray)	2076	(May be performed at any time after serialization)	100%
15	External Visual Inspection	2071		

Notes:

- 1) QR217 Group A subgroups 2 and 3 end point tests as per device detail spec.
- 2) 10000G force for devices with power rating >10 watts at Tc=25°C.
- 3) PDA (percentage defects allowable) is 5% between steps 8 & 10 and 10 & 12.
- 4) Zener diodes shall be subjected to high temperature reverse bias at 80 - 85 percent of nominal VZ for VZ > 10 V. Omit test for devices with VZ ≤ 10 V. For JQRS case mounted rectifiers condition A is required.

10. ESA/ESCC - Space Level Product

Semelab's Space Quality Level Products are based on the testing procedures specified in the generic ESCC 5000 issue 3 and in the corresponding Detail Specifications.

All manufacture and processing is carried out on our approved High-Rel assembly line in our Lutterworth factory and product is released under our ISO 9001:2000 defence standard approval.

The table below shows the additional options which may be required by the customer. All items must be agreed and specified at order stage.

The following pages show the generic chart F2 (component lot manufacturing), chart F3 (screening) and chart F4 (Validation) requirements.

Additional options:

Customer Pre-Cap Visual Inspection	-CVP
Customer Buy-Off visit	-CVB
Data Pack	-DA
Lot Validation Testing (subgroup 1) charge	-LVT1
LVT1 destructive samples (electrical)	-L1DE (normally 15 pieces)
LVT1 destructive samples (mechanical)	-L1DM (normally 15 pieces)
Lot Validation Testing (subgroup 2) charge	-LVT2
LVT2 destructive samples (electrical)	-L2D (normally 15 pieces)
Lot Validation Testing (subgroup 3) charge	-LVT3 (normally 5 pieces)
LVT3 destructive samples (electrical)	
Scanning Electron Microscopy (SEM)	-SEM
Radiography (X-ray)	-XRAY
Total Dose Radiation tests	-RAD

Notes:

- 1) All 'Additional Options' must be specified at order stage
- 2) All 'Additional Options' are chargeable
- 3) All destructive samples are marked the same as other production parts unless otherwise requested.

10.1 Chart F2 - Production Control (ESCC 5000 issue 3)

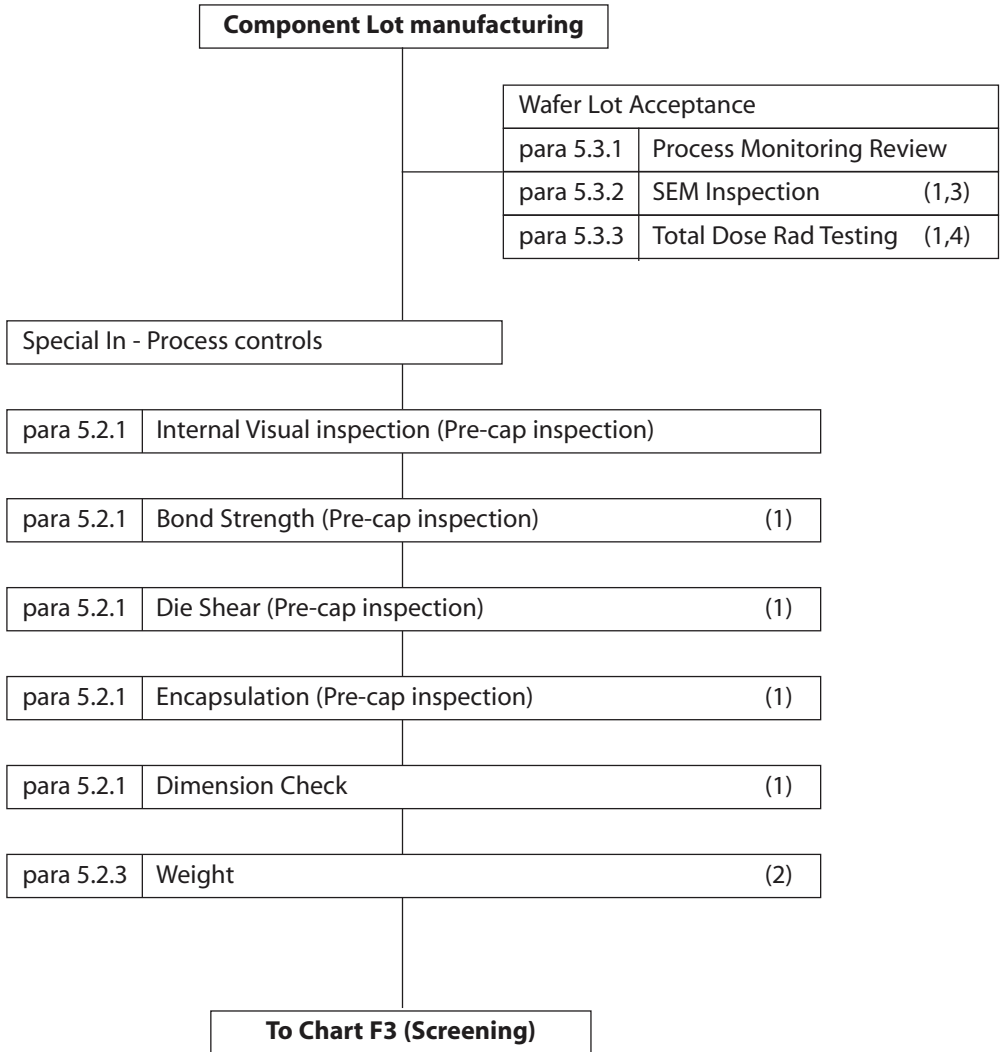

Notes:

- 1) Performed on a sample basis.
- 2) Guaranteed but not tested.
- 3) If specified in the detail specification.
- 4) If specified in the detail specification and required in the Purchase Order.

10.2 ESA/ESCC - Chart F3 Screening (ESCC 5000 issue 3)

Components from Production Control		
para 8.5	High Temperature Stabilisation Bake	
	Electrical Test	(11)
para 8.6.1	Temperature Cycling	
	Acceleration	(10)
para 8.7	Particle Impact Noise Detection (PIND)	
para 8.22	Verification of Safe Operating Area	(2,3)
para 8.9.1	Electrical Measurements, Serialisation and Parameter Drift Values	(1)
para 8.20	High Temperature Reverse Bias Burn-In	(2)
para 8.9.1	Parameter Drift Values HTRB Final and Power Burn-In Initial Measurements	(1)
para 8.21	Power Burn-In	(2)
para 8.9.1	Parameter Drift Values (Final Measurements)	(4)
para 8.9.2	High and Low Temperature Electrical Measurements	(4,5)
	Hot Solder Dip (if applicable)	(6)
para 8.3	Radiographic Inspection	(9)
para 8.8.1&2	Seal (Fine & Gross Leak)	
para 8.9.3	Room Temperature Electrical Measurements (inc AC)	(4,7)
para 6.4.1	Check for Lot Failure	(8)
para 8.10	External Visual Inspection	(8)
para 8.16	Solderability	(4,5)
To Chart F4 (Validation Testing)		

Notes:

- 1) All components shall be serialised prior to Initial Electrical Measurement.
- 2) If specified in detail spec.
- 3) Can be performed at any time prior to initial measurements of Parametric Drift values.
- 4) The Lot Failure criteria of paragraph 6.4 applies to this test.
- 5) Performed on a sample basis.
- 6) Can be performed at any time prior to Room Temp Electrical Measurements during screening (prior to Seal test).
- 7) Measurements of parametric Drift Values need not be repeated in Room Temperature Electrical measurements.
- 8) Check for Lot Failure shall take into account all electrical parameter failures that may occur during screening. Tests in accordance with paragraph 8.9.1, 8.9.2, 8.9.3 subsequent to HTRB Burn-In.
- 9) Radiographic Inspection may be performed at any point during Screening Tests.
- 10) Not specified in ESCC 5000 iss 3, but performed by Semelab to MIL-STD-750 method 2006.
- 11) Not specified in ESCC 5000 iss 3, but performed by Semelab as a process monitor.

10.3 Chart F4 - Validation Testing (ESCC 5000 issue 3)

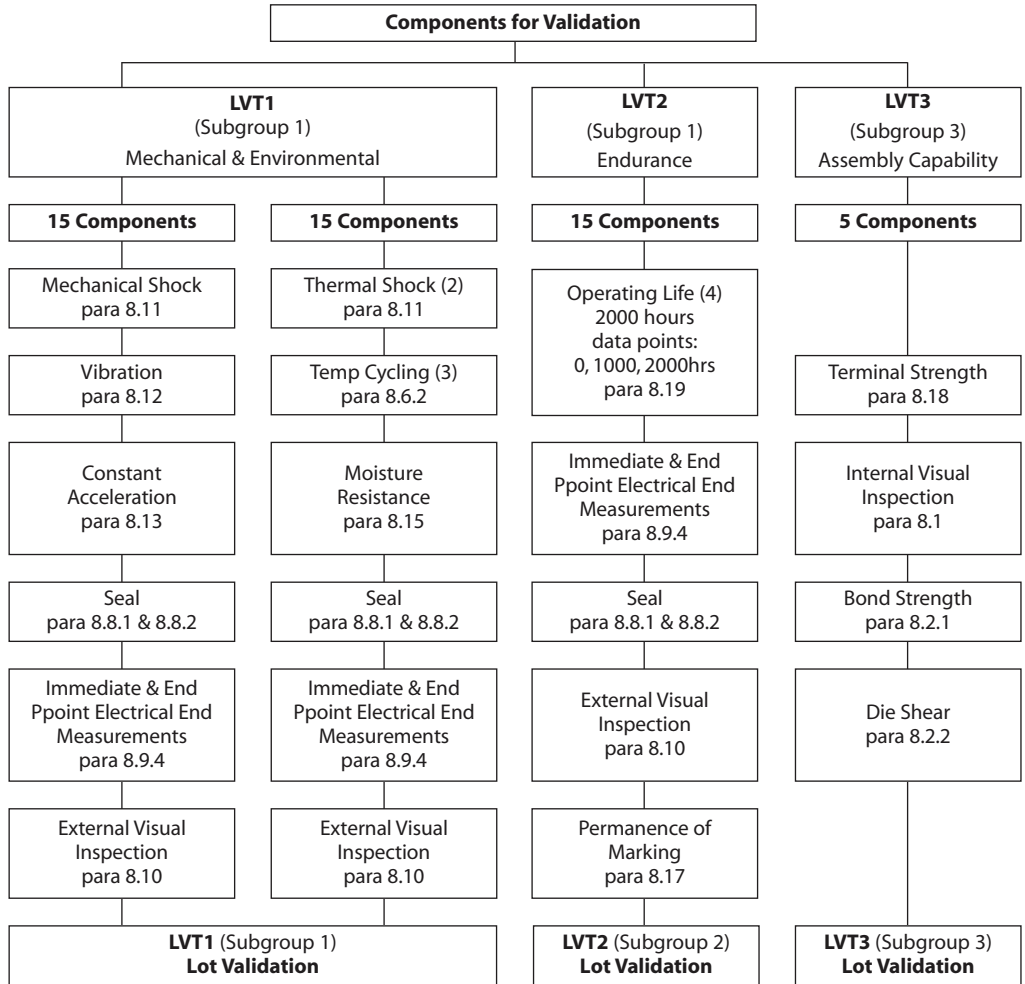

Notes:

- 1) ESCC 5000 iss 3 table F4 - Qualification & Periodic Testing becomes 'Validation Testing' for non qualified parts.
- 2) Only applicable to axial diodes.
- 3) Not applicable to axial lead glass diodes.
- 4) Variance in Test method based on product type.

Ordering Information:

- 1) Order for Subgroup 1 (includes subgroups 2 & 3) requires order for 50 (30+15+5) destructive samples.
- 2) Order for Subgroup 2 (includes subgroup 3) requires order for 20 (15+5) destructive samples.
- 3) Order for Subgroup 3 requires order for 5 destructive samples.
- 4) Other Ordering Options are available - please contact Semelab Sales

11. Screening & Approval Comparison Tables

11.1 Comparison of Space Level Screening Options

Space Level Flow Comparison Table	GENERIC		QR216
	ESCC	JANS*	JQRS
Screening	ESCC	JANS*	JQRS
Pre-cap Visual	●	●	●
Customer pre-cap Visual	OPT	OPT	OPT
High Temp Storage (Stabilization Bake)	24 hrs	24 hrs	24hrs
Temperature cycling	20 cycles	20 cycles	20 cycles
Thermal impedance	OPT	○	-
Constant Acceleration	-	●	●
PIND	●	●	●
Fine/Gross Leak Σ	●	●	●
Serialization	●	●	●
Interim Electrical Measurements	-	-	-
Interim Electrical Measurements (Read and Record / Drift)	●	●	●
HTRB	●	●	●
Electrical Measurements	-	-	-
Parametric Drift measurements (Read and Record / Drift)	●	●	●
Burn-In	min 168 hrs max 264 hrs	240 hrs	240hrs
Electrical Measurements	-	-	-
Parameter Drift Measurements (Read and Record)	●	●	●
PDA Calculations	●	●	●
Read and Record Test Data	●	●	●
Other Electrical Parameters (Temp, Dynamic)	●	●	●
Fine/Gross Leak	●	●	●
Radiography	●	●	●
External Visual Inspection	●	●	●

Notes: ○ if specified in detail specification.
 _ not specified in ESCC 5000 iss 3, but performed by Semelab.

*JANS part not available from Semelab.

Screening & Approval Comparison Tables

11.2 Comparison of Space Level Die Lot Approval Procedures.

The table below shows a comparison of operations carried out for die approval within the generic approval systems (MIL-PRF-19500 space level and ESA / ESCC 5000. It must be noted that SEM and RHA total dose evaluation are options which must be specified if required carry an additional charge.

Space Level/ Die Lot Acceptance Table

Die Lot Acceptance	GENERIC		SML
	ESCC	JANS	JQR-S
Selected Wafer	●	●	●
Probe Test (100%)	●	●	●
Glassivation / Metallization Inspection	●	●	●
Visual Inspection (100%)	●	●	●
Sample Assembly (10 pcs)	●	●	●
Stabilization	●	●	●
Temperature Cycling	●	●	●
Electrical Test (read/record)	●	●	●
HTRB	●	●	●
Electrical Test (read/record)	●	●	●
Steady State Life (1000 hrs)	●	●	●
Electrical Test (read/record)	●	●	●
Wire Bond Evaluation	●	●	●
Die Shear Evaluation	●	●	●
SEM	OPT	OPT	OPT
RHA Total Dose Evaluation	OPT	OPT	OPT

11.3 Comparison of High-Rel Screening Options (Discrete Devices)

The table below shows the comparison of screening options available within the CECC, BS and MIL approvals. Comparison is also shown with Semelab's in-house QR204 options.

	CECC / QR209				BS 9300				QR204		MIL	
	A	B	C	D	A	B	C	D	JQRA	JQRB	JAN* TXV	JAN* TX
Pre-cap Visual	●				●	●			●		●	
High Temp Storage	●	●	●		●	●	●		●	●	●	●
Temperature Cycle	5 cycles	5 cycles	5 cycles		10 cycles	10 cycles	10 cycles		20 cycles	20 cycles	20 cycles	20 cycles
Constant Acceleration	●	●	●		●	●	●		●	●	●	●
Particle impact noise detection (PIND)												
Fine Leak test	●	●	●		●	●	●		●	●	●	●
Gross Leak Test	●	●	●		●	●	●		●	●	●	●
Device Serialisation												
Variables Electrical test	●				●				±	±	±	±
Attributes Electrical tests		●		●		●	●	●	●	●	●	●
Burn-In (HTRB)	168 hrs*	172 hrs*		48 hrs*	160 hrs*	72 hrs*	48 hrs*	48 hrs*	○	○	○	○
Variables Electrical test									±	±	±	±
Attributes Electrical tests									●	●	●	●
Burn-In (Power)	168 hrs*	172 hrs*		48 hrs*	160 hrs*	72 hrs*	48 hrs*	48 hrs*	160 hrs*	160 hrs*	160 hrs*	160 hrs*
Variables Electrical test	●				●				±	±	±	±
Attributes Electrical tests		●		●		●	●	●	●	●	●	●
Radiographic tests					●							

* full JANTX, JANTXV not available from Semelab

● Test Performed

± Test Performed if required by device detail specification

○ 24 hours for PNP devices, 48 hours for NPN devices

* High Temp Reverse Bias for Case rated devices

Power Burn-in for Ambient rated Devices

CECC / QR209 : Screening carried out in accordance with CECC 50000 Appendix 6

BS : Screening carried out in accordance with BS9300 section 1.2.10

QR216 : Screening carried out in accordance with Semelab QR216

QR204 : Screening carried out in accordance with Semelab QR204

MIL : Screening carried out in accordance with MIL-PRF-19500 (Table 2)



Experience and Innovation in Semiconductor Solutions

Specialists In

- Chip design and wafer fabrication
- Plastic packaged devices
- Ceramic surface mount products
- Metal packaged devices
- Power modules
- Standard and custom products
- Screening and qualification
- Continuity of supply

Your Semelab Distributor:



Semelab Limited
Coventry Road,
Lutterworth,
Leicestershire. LE17 4JB
UK

Tel: +44 (0) 1455 556565
Fax: +44 (0) 1455 552612
Email: sales@semelab-tt.com

Web: www.semelab-tt.com

A subsidiary of TT electronics plc.

