

## Enhanced Ultrafast Recovery Diode 600 Volt, 90Amp

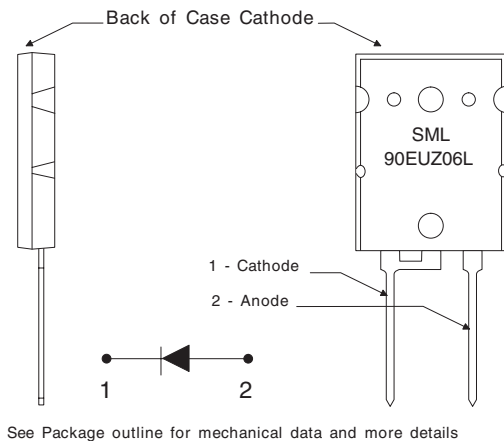

### TO-264 Package

### Key Parameters

$V_R$	(max)	<b>600V</b>
$V_F$	(typ)	<b>2.0V</b>
$I_F$	(max)	<b>90A</b>
$t_{rr}$	(max)	<b>55ns</b>

### TECHNOLOGY

The planar passivated and enhanced ultrafast recovery diode features a triple charge control action utilising Semelab's Graded Buffer Zone technology combined with low emitter efficiency and local lifetime control techniques.

### BENEFITS

- Very fast recovery for low switching losses
- Ultra soft recovery with low EMI generation
- High dynamic ruggedness under all conditions
- Low temperature dependency
- Low on-state losses with positive temperature coefficient
- Stable blocking voltage and low leakage current
- Avalanche rated for high reliability circuit operation

### APPLICATIONS

- Freewheeling Diode for IGBTs and MOSFETs
- Uninterruptible Power Supplies UPS
- Switch Mode Power Supplies SMPS
- Inverse and Clamping Diode
- Snubber Diode
- Fast Switching Rectification

### ABSOLUTE MAXIMUM RATINGS ( $T_{case} = 25^\circ C$ unless otherwise stated)

$V_{RRM}$	Peak Repetitive Reverse Voltage	600V
$V_R$	DC Reverse Blocking Voltage	600V
$I_{FAV}$	Average Forward Current @ $T_C = 85^\circ C$	90A
$I_{FSM(surge)}$	Repetitive Forward Current	225A
$I_{FS(surge)}$	Non-Repetitive Forward Current	900A
$P_D$	Power Dissipation @ $T_C = 85^\circ C$	185W
$W_{AVL}$	Avalanche Energy	50mJ
$T_J, T_{STG}$	Operating & Storage Junction Temperature	-55 to $150^\circ C$

Semelab Plc reserves the right to change test conditions, parameter limits and package dimensions without notice. Information furnished by Semelab is believed to be both accurate and reliable at the time of going to press. However Semelab assumes no responsibility for any errors or omissions discovered in its use. Semelab encourages customers to verify that datasheets are current before placing orders.

## ELECTRICAL CHARACTERISTICS (T<sub>case</sub> = 25°C unless otherwise stated)

Parameter	Test Conditions	Min.	Typ.	Max.	Unit	
<b>STATIC ELECTRICAL CHARACTERISTIC</b>						
V <sub>F</sub>	Forward Voltage Drop	I <sub>F</sub> = 90A      T <sub>j</sub> = 25°C		2	2.5	V
		I <sub>F</sub> = 90A      T <sub>j</sub> = 125°C		2.05		
		I <sub>F</sub> = 50A      T <sub>j</sub> = 25°C		1.6		
I <sub>R</sub>	Leakage Current	V <sub>R</sub> = 600V      T <sub>j</sub> = 25°C		1.5	400	μA
		V <sub>R</sub> = 600V      T <sub>j</sub> = 125°C		1.5	5	mA
C <sub>T</sub>	Junction Capacitance	V <sub>R</sub> = 200V      T <sub>j</sub> = 25°C		123		pF
<b>DYNAMIC ELECTRICAL CHARACTERISTIC</b>						
Q <sub>rr</sub>	Reverse Recovery Charge	V <sub>R</sub> = 300V      I <sub>F</sub> = 90A d <sub>i</sub> / d <sub>t</sub> = 800A/μs      T <sub>J</sub> = 25°C		1.26		μC
I <sub>rr</sub>	Reverse Recovery Current			28		A
t <sub>rr</sub>	Reverse Recovery Time			90		nsec
Q <sub>rr</sub>	Reverse Recovery Charge	V <sub>R</sub> = 300V      I <sub>F</sub> = 90A d <sub>i</sub> / d <sub>t</sub> = 800A/μs      T <sub>J</sub> = 125°C		2.46		μC
I <sub>rr</sub>	Reverse Recovery Current			42		A
t <sub>rr</sub>	Reverse Recovery Time			117		nsec
t <sub>rr</sub>	Reverse Recovery Time	V <sub>R</sub> = 50V      I <sub>F</sub> = 1A d <sub>i</sub> / d <sub>t</sub> = 100A/μs      T <sub>J</sub> = 25°C		55		nsec
<b>THERMAL AND MECHANICAL CHARACTERISTICS</b>						
R <sub>θjc</sub>	Junction to Case Thermal Resistance			0.4		°C/W
T <sub>L</sub>	Lead Temperature			300		°C
L <sub>S</sub>	Stray Inductance		10			nH
Torque	Mounting Torque			1.1		N.m

TO-264 Package Outline

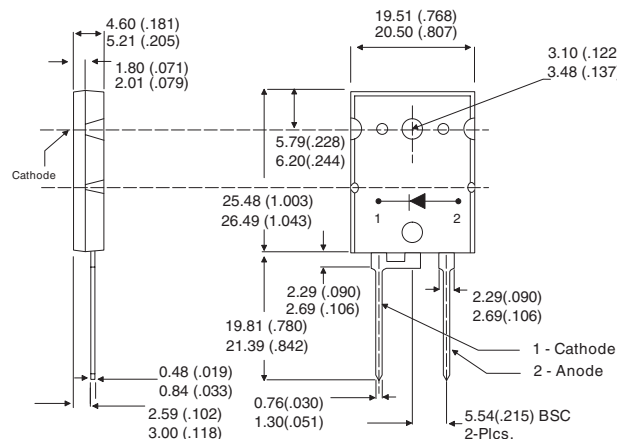

Dimensions in Millimeters and (Inches)

Semelab Plc reserves the right to change test conditions, parameter limits and package dimensions without notice. Information furnished by Semelab is believed to be both accurate and reliable at the time of going to press. However Semelab assumes no responsibility for any errors or omissions discovered in its use. Semelab encourages customers to verify that datasheets are current before placing orders.