

## MECHANICAL DATA

Dimensions in mm (inches)

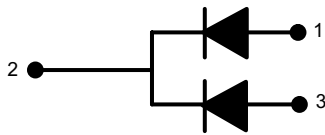
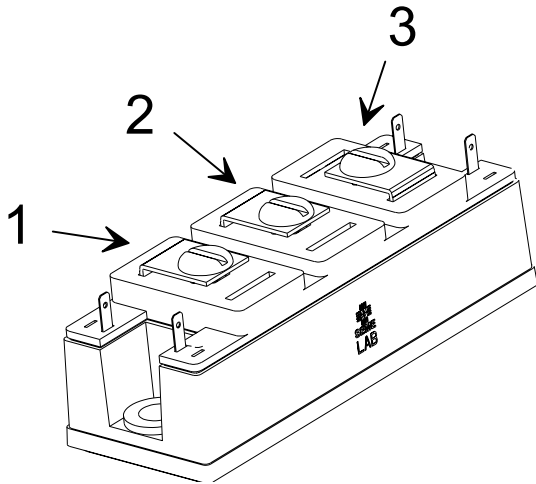

## Ultrafast Recovery Diode Module 300 Volt, 150 Amp

### TECHNOLOGY

This diode module employs ultrafast technology and offers high speed switching combined with low  $V_f$  and very low EMI. It comes in an E34 package and enables easy connection of multiple devices in standard configurations. Parallel operation is problem-free because Semelab diodes have a positive temperature coefficient of  $V_f$ .

### BENEFITS

- Very fast recovery for low switching losses
- Ultra soft recovery with low EMI generation
- High dynamic ruggedness under all conditions
- Low temperature dependency
- Low on-state losses with positive temperature coefficient
- Stable blocking voltage and low leakage current
- Avalanche rated for high reliability circuit operation

### Key Parameters

$V_R$	(max)	300V
$V_F$	(typ)	1.4V
$I_F$	(max)	150A
$t_{rr}$	(max)	50nS

### APPLICATIONS

- Freewheeling diode in converters and motor control circuits
- Uninterruptible power supplies UPS
- Antiparallel diode for high frequency switching devices
- Inductive heating and melting

## ABSOLUTE MAXIMUM RATINGS (T<sub>case</sub> = 25°C unless otherwise stated)

$V_{RRM}$	Peak Repetitive Reverse Voltage	300V
$V_R$	DC Reverse Blocking Voltage	300V
$I_{FAV}$	Average Forward Current @T <sub>C</sub> = 85°C	150A
$I_{FSM(surge)}$	Repetitive Forward Current	400A
$I_{FS(surge)}$	Non-Repetitive Forward Current(10msec pulse)	1500A
$P_D$	Power Dissipation @T <sub>C</sub> = 85°C	220W
$T_J, T_{STG}$	Operating & Storage Junction Temperature	-55 to 150°C

Semelab Plc reserves the right to change test conditions, parameter limits and package dimensions without notice. Information furnished by Semelab is believed to be both accurate and reliable at the time of going to press. However Semelab assumes no responsibility for any errors or omissions discovered in its use. Semelab encourages customers to verify that datasheets are current before placing orders.

## ELECTRICAL CHARACTERISTICS (T<sub>case</sub> = 25°C unless otherwise stated)

Parameter	Test Conditions	Min.	Typ.	Max.	Unit
<b>STATIC ELECTRICAL CHARACTERISTIC</b>					
V <sub>F</sub> * Forward Voltage Drop	I <sub>F</sub> = 150A T <sub>J</sub> = 25°C		1.4	2	V
	I <sub>F</sub> = 150A T <sub>J</sub> = 125°C		1.45		
	I <sub>F</sub> = 100A T <sub>J</sub> = 25°C		1.2		
I <sub>R</sub> Leakage Current	V <sub>R</sub> = 300V T <sub>J</sub> = 25°C		1	400	μA
	V <sub>R</sub> = 300V T <sub>J</sub> = 125°C		0.7	5	mA
C <sub>T</sub> Junction Capacitance	V <sub>R</sub> = 200V T <sub>J</sub> = 25°C		125		pF
<b>DYNAMIC ELECTRICAL CHARACTERISTIC</b>					
Q <sub>rr</sub> Reverse Recovery Charge	V <sub>R</sub> = 200V I <sub>F</sub> = 150A d <sub>i</sub> / d <sub>t</sub> = 1200A/μs T <sub>J</sub> = 25°C		3.26		μC
I <sub>rr</sub> Reverse Recovery Current			50		A
t <sub>rr</sub> Reverse Recovery Time			260		nsec
Q <sub>rr</sub> Reverse Recovery Charge	V <sub>R</sub> = 200V I <sub>F</sub> = 150A d <sub>i</sub> / d <sub>t</sub> = 1200A/μs T <sub>J</sub> = 25°C		6.34		μC
I <sub>rr</sub> Reverse Recovery Current			76		A
t <sub>rr</sub> Reverse Recovery Time			340		nsec
t <sub>rr</sub> Reverse Recovery Time	V <sub>R</sub> = 50V I <sub>F</sub> = 1A d <sub>i</sub> / d <sub>t</sub> = 200A/μs T <sub>J</sub> = 25°C		100		nsec
<b>THERMAL AND MECHANICAL CHARACTERISTICS</b>					
R <sub>θjc</sub> Junction to Case Thermal Resistance			TBA		°C/W
R <sub>θja</sub> Junction to Ambient Thermal Resistance			TBA		

## Package Outline Drawing

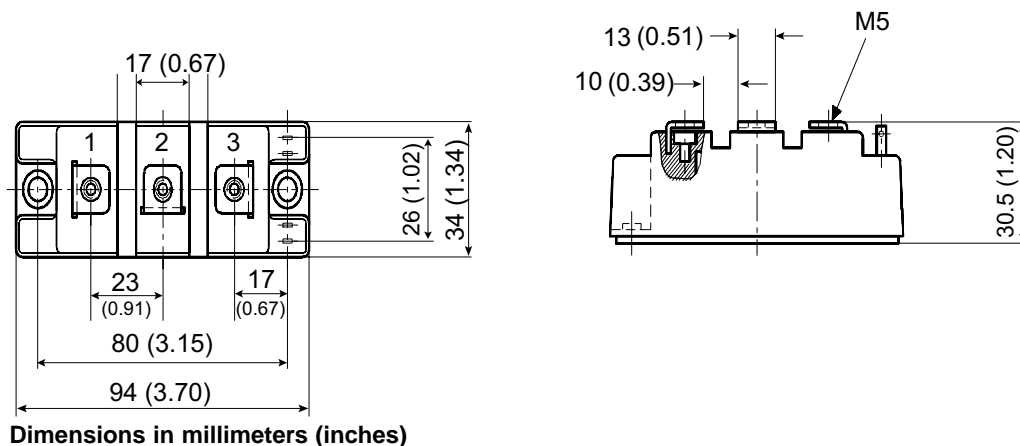

Semelab Plc reserves the right to change test conditions, parameter limits and package dimensions without notice. Information furnished by Semelab is believed to be both accurate and reliable at the time of going to press. However Semelab assumes no responsibility for any errors or omissions discovered in its use. Semelab encourages customers to verify that datasheets are current before placing orders.